

OPERATION MANUAL

REMOTE CONTROLLER

MODEL R C O 2 - C O M

KIKUSUI ELECTRONICS CORPORATION

(KIKUSUI PART NO. Z1-996-820)

IA002211

Power Requirements of this Product

Power requirements of this product have been changed and the relevant sections of the Operation Manual should be revised accordingly.

(Revision should be applied to items indicated by a check mark)

Input voltage

The input voltage of this product is _____ VAC,
and the voltage range is _____ to _____ VAC. Use the product within this range only.

Input fuse

The rating of this product's input fuse is _____ A, _____ VAC, and _____.

WARNING

- To avoid electrical shock, always disconnect the AC power cable or turn off the switch on the switchboard before attempting to check or replace the fuse.
- Use a fuse element having a shape, rating, and characteristics suitable for this product. The use of a fuse with a different rating or one that short circuits the fuse holder may result in fire, electric shock, or irreparable damage.

AC power cable

The product is provided with AC power cables described below. If the cable has no power plug, attach a power plug or crimp-style terminals to the cable in accordance with the wire colors specified in the drawing.

WARNING

- The attachment of a power plug or crimp-style terminals must be carried out by qualified personnel.

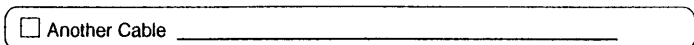
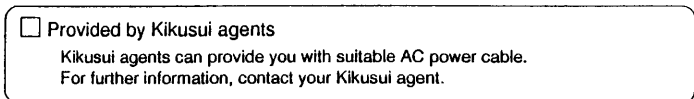
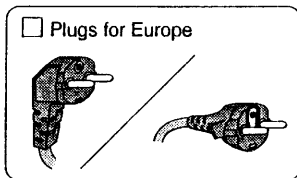
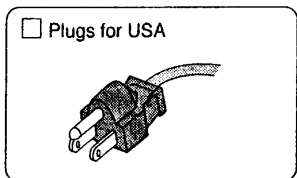
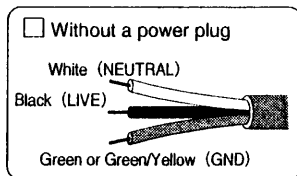
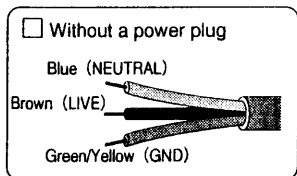

CONTENTS

	PAGE
1. GENERAL	1
1.1 General Description	1
1.2 Features	1
2. SPECIFICATIONS	3
3. GENERAL PRECAUTIONS	6
4. OPERATION INSTRUCTIONS	7
4.1 Hooking up to Oscilloscope	7
4.2 Functions of Keys	10
4.3 Operating Procedures	11
4.3.1 To Write Panel Setting Data	11
4.3.2 To Read Panel Setting Data	13
4.3.3 Automatic Increment Mode	15
4.3.4 Copying Of Step Memory Data	15
4.4 Others	17

1. GENERAL

1.1 General Description

The RCO2-COM Remote Controller is used to remote-control or store setting data of panel items of a COM7202A Digital Oscilloscope. The RCO2-COM may be used also in conjunction with a PS01-COM Probe Selector.

1.2 Features

The RCO2-COM Remote Controller is compact and can be conveniently used for programmed remote control of an oscilloscope for research and development in a laboratory as well as it can be used as a fixed installation on a manufacturing or inspection line in a factory. The features of the RCO2-COM includes the following:

(1) Step Control

The RCO2-COM allows to store up to 100 steps of panel settings in memory of a COM7202A Oscilloscope by specifying addresses for them, and allows to read and copy them. It also allows loop operation by specifying a start address and an end address.

(2) Probe Selection

By using a PS01-COM Probe Selector (optional), selection of probes can be remote-controlled and its data can be stored in step memory.

(3) Position Control

The positions of the (CH1-CH4) vertical, horizontal and two positions of cursors of the COM7202A can be easily controlled by the RCO2-COM. And these set-up positions may be stored by COM7202A unit.

(4) Automatic Increment

The RCO2-COM allows automatic increment of steps between preset start and end steps in selectable time intervals.

(5) Protect Switches

The RCO2-COM has DIP switches which disables certain keys of the RCO2-COM or front panel settings of the COM7202A.

(6) Connector for BCD Output and Control Inputs

A connector is provided for a BCD step address signal and for reset, increment and decrement switch signals (such as of pedal switches).

(7) External Step Control

This function allows to perform the function of Item (1) "Step Control" by using an external device such as a jig or a personal computer.

Up to 100 different addresses can be specified with an external signal of a BCD type or a binary coded parallel type.

2. SPECIFICATIONS

- (1) Memory Steps: 100 steps (100 types of settings)
- (2) Stored Items: Settings of all items except those of INTEN, FOCUS and TRACE ROTATION can be stored in memory.
- (3) Probe Select Function: Probe selection with PS01-COM Probe Selector can be externally controlled.
- (4) Step Address Display: 00-99 (with 7-segment LED readout)
- (5) Control Functions
- COPY: Transfer of setting data between a start step address and an end step address.
 - WR: To write set data in memory.
 - STAT: To set address range (start address).
 - END: To set address range (end address).
 - PROB: To set the probe number to be selected.
 - CONT: To select POSITION control or automatic increment mode for address change.
 - RESET: To reset to the START address.
To reset from command mode.
 - DEC: To decrement step address by one step.
 - INC: To increment step address by one step.
- (6) Remote Control Function: Remote control of CH1, CH2, CH3 and CH4 vertical and horizontal positions, REF or DLY position, and Δ cursor position. Automatic step address increment.
- (7) Protective Function: Disables COM7202A front panel controls and RCO2-COM command keys and tenkeys
- (8) Step Address Output: BCD code, TTL level, negative logic
※ When protect switch No. 5 is in top position (OFF)
- (9) Step Address Control:
- Input Signal: C-MOS level (0, +5V)
 - Control Signal: C-MOS level (0, +5V)
 - Input Data: Selectable between binary code and BCD code (common connector for inputs and outputs), positive logic
 - External Input Enable: Negative logic

Input Connector: 5063PBT (terminals), 5264-15 (housing) manufactured by MOLEX

Input/Output Circuit: (See the next page.)

Timing: (See the next page.)

※ When protect switch No. 5 is in bottom position (ON)

(10) Overall Dimensions

Excluding Extrusions: 155 W × 73 H × 21 D mm
(6.10 W × 2.87 H × 0.83 D in.)

Including Extrusions: 155 W × 86 H × 36 D mm
(6.10 W × 3.39 H × 1.42 D in.)

5
5
1
1
1

Input/Output Circuit

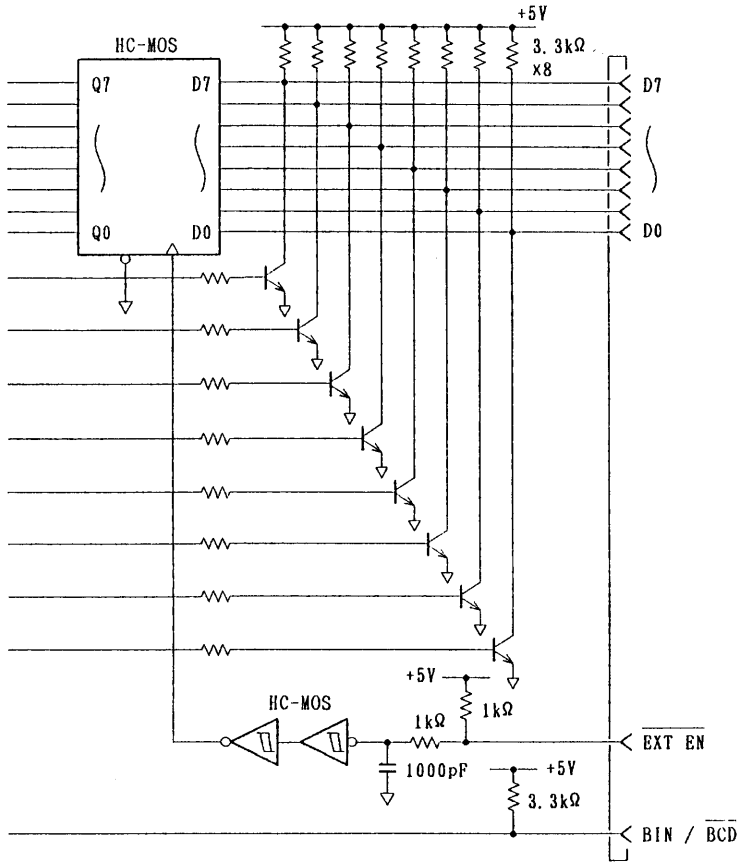

Timing

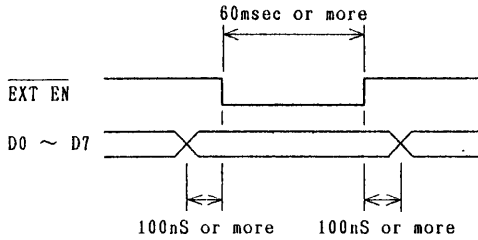

917700

3. GENERAL PRECAUTIONS

3.1 Unpacking the Instrument

The instrument is shipped from the factory after being fully inspected and tested. Upon receipt of the instrument, immediately unpack and inspect it for any damage which might have been sustained when in transportation. If any sign of damage is found, immediately notify the bearer and/or the dealer.

3.2 Environments

The normal ambient temperature range of this instrument is 0 to 50°C (32 to 122°F). Operation of the instrument outside of this temperature range may cause damage to the circuits.

Do not use the instrument in a place where strong magnetic or electric field exists. Such fields may disturb the measurement.

4. OPERATION INSTRUCTIONS

4.1 To Connect RC02-COM to COM7202A

To hook up the RC02-COM Remote Controller to the COM7202A Oscilloscope, connect the remote controller cable or probe selector cable to the REMOTE connector (64) on the rear panel of the Oscilloscope. Power for the remote controller will be supplied from the oscilloscope. A step address which indicates the state of connection of the remote controller will appear on the CRT of the oscilloscope.

Note: Be sure to turn off the POWER switch of the COM7202A before connecting the cable to hook up the RC02-COM or PSO1-COM.

Note that the instruments may be damaged if the cable is connected without turning off the switch.

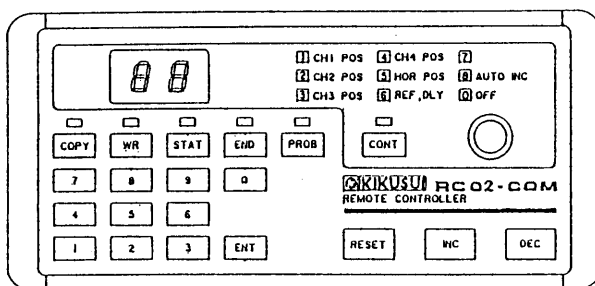

Top Panel of RC02-COM Remote Controller

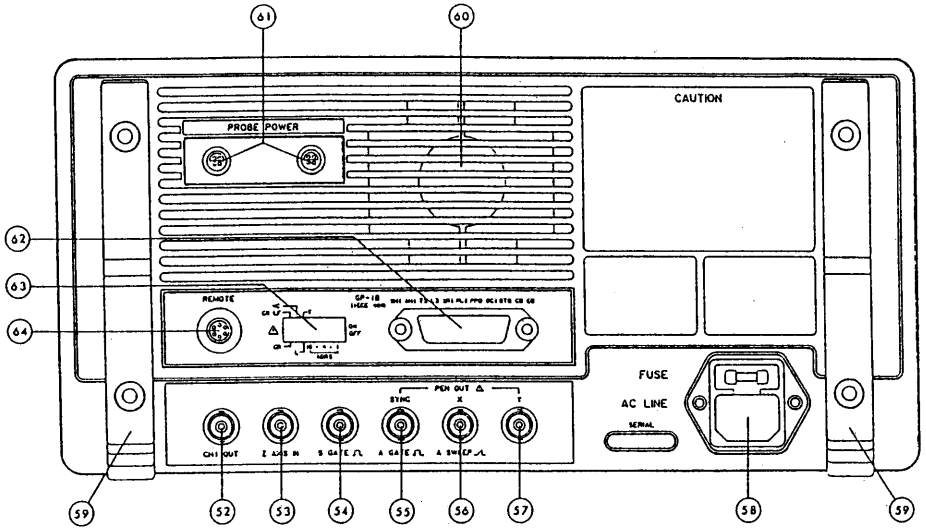

Rear Panel of COM7202A Oscilloscope
 (identical with Figure 4-3 of COM7202A Instruction Manual)

0111100

To hook up the RC02-COM Remote Controller alone or both RC02-COM Remote Controller and PS01-COM Probe Selector to the COM7202A Oscilloscope, connected them as illustrated below.

- (1) To hook up the RC02-COM alone

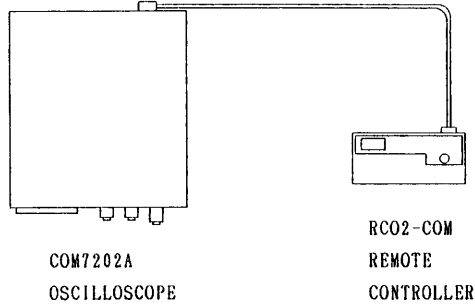

- (2) To hook up both PS01-COM and RC02-COM

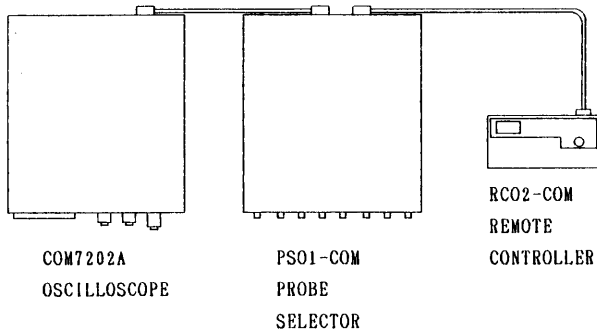

4.2 Functions of Keys

The RCO2-COM Remote Controller has command keys to select the required mode, tenkeys to enter data, and step control keys to control step address increment and decrement. To operate the system, you may manipulate command keys and tenkeys first and step control keys next. The functions of these keys are described in more detail in the following:

(1) Command Keys (COPY, WR, START, END, PROB, CONT):

As you press one of the command keys, its LED lamp illuminates to indicate that the corresponding mode has been selected and the 7-segment LED readout displays the stored data.

If you press another command key at a halfway of procedure for setting to the mode for the key pressed precedingly, the preceding setting procedure is aborted and the instrument is set to the mode for the key pressed newly. The stored data of the aborted mode remains intact.

(2) Tenkeys (0 - 9, ENT)

These keys are for entry of numerical code as data for setting or control. To enter data, press the tenkeys for the required numerical code and then press the ENT key. You may press ENT key alone without entering any numerical code, in which case the previously stored data remains intact and is displayed on the 7-segment LED readout allowing you to confirm it.

When you have pressed wrong tenkeys and a wrong numerical code is displayed on the readout, just press the correct tenkeys newly and the old wrong code will be automatically replaced by the new correct code as displayed on the readout.

(3) Step Control Keys (RESET, INC, DEC)

These keys are used to reset, increment or decrement step addresses in order to control the COM7202A Oscilloscope with data stored in such addresses. Each time as you press the INC or DEC key, the addresses between the ones specified by the START and END commands are incremented or decremented by one step. As you press the RESET key, address is unconditionally reset to the START address or, if the RCO2-COM is in a command mode, it is reset from the command mode.

4.3 Operating Procedures

When power of the COM7202A Oscilloscope is turned on, the oscilloscope is driven into the states conforming with the panel backup data stored in the oscilloscope. Then, the oscilloscope can be controlled remotely from the front panel of the RC02-COM Remote Controller.

4.3.1 To Write Panel Setting Data

[1] Setting the Probe Selector

- (1) Press the PROB key to set the RC02-COM to the PROBE command mode, and the readout will display "A" to indicate the set probe number of the A group.
- (2) Press one of the tenkeys (1-8) corresponding to the probe number of the A group to be set.
- (3) Press the ENT key, and the data entry for the A group will be complete and the readout will display "B" to indicate the set probe number of the B group.
- (4) Press one of the tenkeys (1-8) corresponding to the probe number of the B group to be set.
- (5) Press the ENT key, and the data entry for the B group will be complete, the readout will return to the initial state, and the command mode will end.

[2] Selecting a Position Control

- (1) Press the CONT key to set the RC02-COM to the CONTROL command mode.
- (2) Press tenkeys (0-8) corresponding to the code number of the position control to be selected.
- (3) Press the ENT key to enter the position control code number. When the above procedure is complete, the selected position control is adjustable.

To select another position control, press the CONT key again and then repeat the above procedure.

- (4) Before adjusting the position control(s), select the required channel(s) at the front panel of the COM7202A.

[3] To Write Panel Setting Data

- (1) Set the front panel items of the COM7202A Oscilloscope in the states which are to be stored in memory.
- (2) Press the WR key to set the RCO2-COM to the WRITE command mode.
- (3) Press tenkeys (0-9) for the address where the panel setting data is to be stored.
- (4) Press the ENT key, and the data will be stored at the above address. The readout will indicate the next address.
- (5) Set the front panel items of the COM7202A Oscilloscope in the states for the next step of memory.

Note: If setting of the Probe Selector or position control also is required to be changed, reset the RCO2-COM once from the WRITE command mode.

- (6) Repeat the procedure starting by (4).
- (7) Press the RESET key to reset the RCO2-COM from the WRITE command mode.

904423

4.3.2 To Read Panel Setting Data

[1] Setting the Start Address and End Address

Note: If the START address code number is larger than the END address code number, an error status will occur (the readout will indicate "--"). If this is the case, set the END address first and the START address next.

- (1) Press the START or END key to set the RCO2-COM to the command mode.
- (2) Press tenkeys (0 - 9) for the address code number.
- (3) Press the ENT key to enter the address code number.

The START and END address code numbers entered as above are protected even when the POWER switch of RCO2-COM is turned off.

When the START and END addresses have been set as above, the addresses between them can be sequentially read by pressing the INC or DEC step control key.

[2] To Read Panel Setting Data

- (1) Press the RESET key to read the panel setting data stored at the START address.
- (2) Press the INC or DEC key to increment (+1) or decrement (-1) the address code number.

To jump to an address which you may require, press tenkeys (0 - 9) for the address code number and then press the ENT key. Increment or decrement of address code number thereafter is as illustrated below.

427706

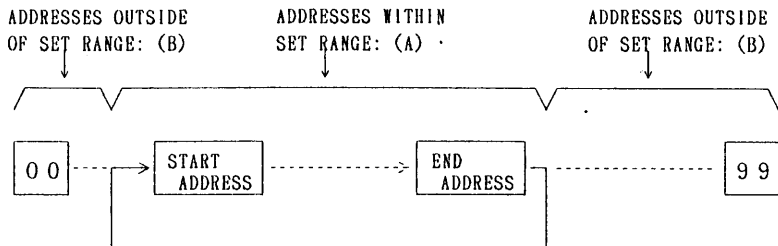

Case (A): This case is that one of the addresses within the range set by the START and END addresses is specified and then the ENT key is pressed. Address number will be incremented or decremented by 1 starting by the specified address within the set range as you press the INC or DEC key, respectively.

Example: Assume that 10 is set for the START address and 20 for the END address and that 15 is specified for the current address. As you press the INC or DEC key, address number will be incremented to 16, 17, 18 and so forth or decremented to 14, 13, 12 and so forth, respectively.

Case (B): This case is that one of the addresses outside of the range set by the START and END addresses is specified and then the ENT key is pressed. Address number will be incremented or decremented starting by the address which has been displayed latest (the current address) as you press the INC or DEC key, respectively.

Example: Assume that 10 is set for the START address and 20 for the END address, address number has been incremented to 15 by pressing the INC or DEC key and, at this instant, you have specified address number 25 which is outside of the set range. As you press the INC or DEC key, address number will be incremented to 16, 17, 18 and so forth or decremented to 14, 13, 12 and so forth, respectively; by returning the scanning to within the set address range of 10-20.

001105

4.3.3 Automatic Increment Mode

If you select No.8 for position control setting, the RCO2-COM is set to the automatic increment mode and the address code number is automatically and sequentially incremented in 1-steps. The incrementing speed is adjustable for a range of approximately 1-30 seconds per step with the read speed control knob.

To abort or reset from the automatic increment mode, press the RESET key.

Note: The automatic increment mode of operation is not programmable (no data for this mode of operation can be stored in memory).

The functions of specifying an arbitrary address number for the current address (for the starting point of the current address scanning) and subsequent automatic address increments basically are identical with those of Section 4.3.2, [2], (2).

4.3.4 Copying of Step Memory Data

Data between the START and END addresses can be copied to addresses following an address you specify. If address code number exceeds 99 or copying to the same address numbers is specified, an error status results (the readout indicates "--").

When data blocks of the original addresses are overlapped on those of the copy addresses, they are copied in a manner that they are not destroyed as illustrated below. Thus, data can be freely inserted or deleted.

- (1) Define a range of the original to be copied, by specifying a START and END addresses in the same procedure as described in Section 4.3.2 [1].
- (2) Press the COPY key to set the instrument to the COPY command mode.
- (3) Specify the start address of memory onto which the data is to be copied, using tenkeys 0-9.
- (4) Press the ENT key to declare the end of entry.

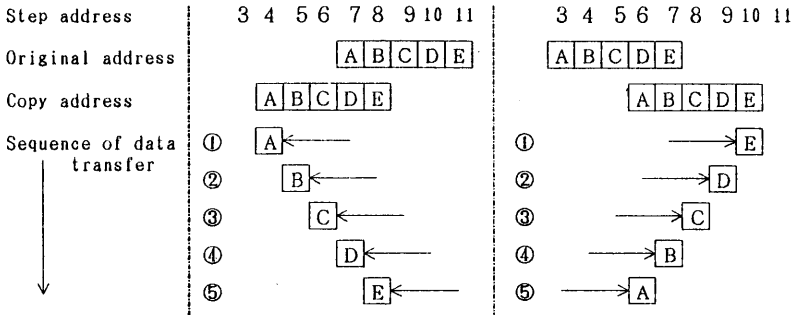

Note: Note for storing of VARIABLE CONTROL data of CH1, CH2 vertical sensitivity and TIME BASE

The VARIABLE (vernier) controls on the COM7202A front panel have two positions, namely, pushed-out position (UNCAL position for vernier adjustment) and pushed-in position (CAL position for fixed value). The RCO2-COM allows you to store data of settings of the controls even when they are pushed-in position. The controls may often be used being set in the pushed-in position, also. Since no provisions for mechanically pushing in or out the controls are provided, disparities may occur between the read panel setting data and actual positions of the controls. These disparities, however, do not cause any functional detriments to the remote control system. When you want to change the vernier setting of a control, push it out to the UNCAL position and then adjust it to the setting you may require.

4011000

4.4 Others

(1) Protect Switches

The protect switches disable (when in the top (OFF) position) or enable (when in the bottom (ON) position) the front panel keys of COM7202A and the command keys of RCO2-COM as follows:

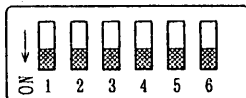

- Switch No. 1: Disables or enables the START, END, PROB, and CONT keys.
- Switch No. 2: Disables or enables the tenkeys.
- Switch No. 3: Disables or enables the front panel setting functions of COM7202A.
- Switch No. 4: Disables or enables the COPY and WR keys.
- Switch No. 5: Disables or enables the external step control function
- Switch No. 6: Not used

Example: For an oscilloscope system which is used on a manufacturing line and the step memory is required to be set to a read-only mode in order to be protected against inadvertent or unauthorized changes, throw protect switches Nos. 1 and 4 to the top (OFF) position.

(2) Connector for BCD Output, BCD Input, Binary Input, and External Step Control Input

- o Turn on the powers of the system devices in the order of the external devices (jigs, personal computer, etc.) first and the COM7202A last, or turn them on simultaneously.
- o An address error of BCD code or binary code is displayed with symbol "--". When this symbol has appeared, repeat setting the oscilloscope or clear the setting by pressing the RESET key.

The layout and functions of the connector for the BCD output and control inputs are as follows:

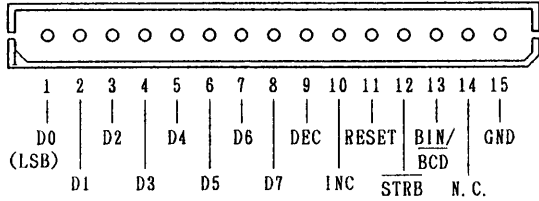

Inputs : $D_0 - D_7$: Address inputs, C-MOS level, positive logic

Outputs : $D_0 - D_3$: LSD (order of 1), TTL level output, negative logic

$D_4 - D_7$: MSD (order of 10), TTL level output, negative logic

$\overline{\text{EXT EN}}$: External input enabled, C-MOS level input, negative logic

$\overline{\text{BIN/BCD}}$: Select between binary and BCD address codes
 ["OPEN" for binary, "L" for BCD]

RESET: For function identical with that of the RESET key.
EXTERNAL CONTROL INPUT



INC: For function identical with that of the INC key.
EXTERNAL CONTROL INPUT

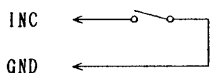

DEC: For function identical with that of the DEC key.
EXTERNAL CONTROL INPUT

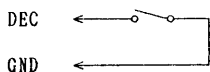

Applicable connector: Manufactured by MOLEX
Housing 5264-15
Terminals 5263PBT